



## GRID SYNCHRONIZATION METHOD FOR THREE-PHASE THREE-WIRE NETWORKS UNDER GRID FAULT CONDITION

1. NELAGUDUTI UPENDAR<sup>1</sup>, 2. RAMAVATH SHANKAR NAIK

1.Pg Scholar, Department of EEE, SLC's Institute of Engineering and Technology,Hyderabad.

.2.Associate Professor& HOD, Department Of EEE, SLC's Institute of Engineering and Technology, Hyderabad

### ABSTRACT:

Grid synchronization algorithms are of great importance in the control of grid-connected power converters, as fast and accurate detection of the grid voltage parameters is crucial in order to implement stable control strategies under generic grid conditions. This paper presents a new grid synchronization method for three-phase three-wire networks, namely three-phase enhanced PLL. The enhanced phase-locked loop (EPLL) is a synchronization system that has proven to provide good results in single phase synchronization systems. An EPLL is essentially an adaptive band pass filter, which is able to adjust the cutoff frequency as a function of the input signal. Its structure was later adapted for the three-phase case, in order to detect the positive-sequence vector of three-phase signals, This paper analyses the performance of the proposed synchronization method including different design issues. Moreover, the behavior of the method for synchronizing with highly unbalanced grid is proven by means of simulation demonstrating its excellent performance.

### INTRODUCTION

Nowadays, the use of power electronics and information and communication technology (ICT) applications are key issues in the development of future electrical networks. The high penetration of renewable energy sources such as wind power and photovoltaic, experienced in the last decades is a good example, as both generation systems are connected to the grid by means of power electronics-based power processors, that should not only control the power delivered to the network, but also contribute to the grid stability, supporting the grid services voltage/frequency under generic conditions, even under grid faults. One of the most important issues in the connection of power converters to the grid is the synchronization with the grid voltage at the point of common coupling (PCC). Although the grid voltage waveforms are sinusoidal and balanced under regular operating conditions, they can easily become unbalanced and distorted due to the effect of grid faults and nonlinear loads. Under these conditions, grid-connected converters should be properly synchronized with the grid in order to stay actively connected, supporting the grid services and keeping the generation up and running



.Actually, these are currently former requirements in all grid codes (GCs) for the connection of distributed generation systems to the network, where the criteria for the injection of active and reactive power during either balanced or unbalanced grid fault conditions are also provided. Despite the fact that the dynamics of grid synchronization are not established in the GC, requirements are needed in order to achieve a certain dynamical response in the synchronization. Algorithms based on the implementation of phaselocked loops (PLL) have traditionally been used for synchronizing the control system of power converters with the grid voltage. In Fig. 1, the layout of a generic control structure for a three phase power converter connected to the grid is shown. As depicted in Fig. 1, the grid synchronization block is responsible for estimating the magnitude frequency and phase angle of the positive- and the negative- sequence components of the grid voltage,  $v_{\pm}$ ,  $\omega$ , and  $\theta_{\pm}$ , respectively. These estimated values are later used at the current controller block, which settles finally the voltage waveform to be modulated  $v^* c$  as well as at the reference generator, responsible of determining the current reference to be tracked. This last block will vary if the power converter is acting as an active filter, a STATCOM, or a power processor belonging to a power generation plant. In three-phase systems, a PLL based on a synchronous reference frame (SRF-PLL) has become a conventional grid synchronization technique. Nevertheless, the response of the SRF-PLL is unacceptably deficient when the grid voltage is unbalanced due to the appearance of a negative-sequence component that the SRF-PLL is unable to process properly. In order to solve this problem, different advanced grid synchronization systems have recently been proposed. This is the case of the decoupled double SRF PLL (DDSRFP LL), an extension of the SRF- PLL, which uses two SRFs and a decoupling network to isolate the effects of the positive and the negative- sequence voltage components. Another interesting synchronization technique was presented in, where three single-phase enhanced PLLs are combined with a positive sequence calculator to synchronize with unbalanced and distorted three-phase networks without using any SRF. Considering the same structure, other single-phase PLL approaches, like those presented in, can be used to provide the input signals to the positive-sequence calculation algorithm. Likewise, other synchronization structures have been proposed for three-phase systems based on PLL, as those published in. However, the dynamical response of these algorithms is very sensitive to phase angle jumps in the voltage at the PCC due the fact that the PLL is synchronizing with this variable. This is a serious drawback, as sudden phase angle changes are prone to happen when a fault occurs, due to the change in the network impedance. In this paper, a new approach using frequency locking instead of conventional phase locking will be presented as an effective solution for grid synchronization under adverse grid conditions

## PROBLEM IDENTIFIED

DES technologies have very different issues compared with traditional centralized power sources. For example, they are applied to the mains or the loads with voltage of 480 volts or less; and require power



converters and different strategies of control and dispatch. All of these energy technologies provide a DC output which requires power electronic interfaces with the distribution power networks and its loads. In most cases the conversion is performed by using a voltage source inverter (VSI) with a possibility of pulse width modulation (PWM) that provides fast regulation for voltage magnitude. Power electronic interfaces introduce new control issues, but at the same time, new possibilities. For example, a system which consists of micro-generators and storage devices could be designed to operate in both an autonomous mode and connected to the power grid. One large class of problems is related to the fact that the power sources such as micro turbines and fuel cell have slow response and their inertia is much less. It must be remembered that the current power systems have storage in generators' inertia, and this may result in a slight reduction in system frequency. As these generators become more compact, the need to link them to lower network voltage is significantly increasing. However, without any medium voltage networks adaptation, this fast expansion can affect the quality of supply as well as the public and equipment safety because distribution networks have not been designed to connect a significant amount of generation. Therefore, a new voltage control system to facilitate the connection of distributed generation resources to distribution networks should be developed. In many cases there are also major technical barriers to operating independently in a standalone AC system, or to connecting small generation systems to the electrical distribution network with lower voltage, and the recent research issues include: 1. Control strategy to facilitate the connection of distributed generation resources to distribution networks. 2. Efficient battery control. 3. Inverter control based on only local information. 4. Synchronization with the utility mains. 5. Compensation of the reactive power and higher harmonic components. 6. Power Factor Correction. 7. System protection. 8. Load sharing. 9. Reliability of communication. 10. Requirements of the customer. DES offers significant research and engineering challenges in solving these problems. Moreover, the electrical and economic relationships between customers and the distribution utility and among customers may take forms quite distinct from those we know today. For example, rather than devices being individually interconnected in parallel with the grid, they may be grouped with loads in a semi- autonomous neighborhood that could be termed a micro grid is a cluster of small sources, storage systems, and loads which presents itself to the grid as a legitimate single entity. Hence, future research work will focus on solving the above issues so that DES with more advantages compared with traditional large power plants can thrive in the electric power industry.

## PROBLEM DESCRIPTION

These new distributed generations interconnected to the low grid voltage or low load voltage cause new problems which require innovative approaches to managing and operating the distributed resources. In the fields of Power Electronics, the recent papers have focused on applications of a standby generation, a standalone AC system, a combined heat and power (cogeneration) system, and interconnection with the grid of distributed generations on the distribution network, and have suggested technical solutions



which would permit to connect more generators on the network in good conditions and to perform a good voltage regulation. Depending on the load, generation level, and local connection conditions, each generator can cause the problems described in the previous chapter. The main goals which should be achieved will thus be: to increase the network connection capacity by allowing more consumers and producer customers connection without creating new reinforcement costs, to enhance the reliability of the systems by the protections, to improve the overall quality of supply with a best voltage control.

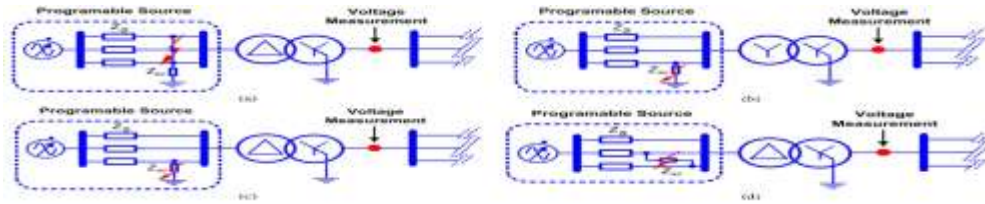

Fig. 1. Generation of grid voltage sags in the experimental setup. (a) Generation of a Type “A” voltage sag. (b) Generation of a Type “B” voltage sag. (c) Generation of a Type “C” voltage sag. (d) Generation of a Type “D” voltage sag

**SOLUTION TO THE PROBLEM**

Facts controllers are the best of solution to that problems. Here we have to control the facts devices by considering different types of PLLS. In this project we develop following EPLL Structure

**3phEPLL Discretization**

The block diagram of the EPLL implemented in this paper is presented in Fig

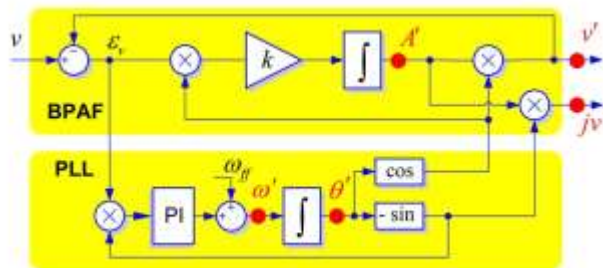

Fig. 2. Quadrature signal generator based on an EPLL structure.



According to this diagram, the state space representation of the EPLL in the continuous domain can be written as shown in

$$\dot{A}'(t) = k \cdot e(t) \cdot \cos \theta'(t)$$

$$\dot{\omega}'(t) = -k_i \cdot e(t) \cdot \sin \theta'(t)$$

$$\dot{\theta}'(t) = \omega'(t) + \frac{k_p}{k_i} \cdot \dot{\omega}'(t).$$

The discrete state space variable representation was described in [44] using a forward Euler approximation to reach satisfactory results; therefore, the same method has been implemented here

$$e[n+1] = u[n+1] - v'[n]$$

$$A'[n+1] = A'[n] + T_s \cdot k \cdot e[n] \cdot \cos(\theta'[n])$$

$$\omega'[n+1] = \omega'[n] - T_s \cdot k_i \cdot e[n] \cdot \sin(\theta'[n])$$

$$\theta'[n+1] = \theta'[n] + T_s \cdot \omega'[n] - T_s \cdot k_p \cdot e[n] \cdot \sin(\theta'[n]).$$

Finally, after the state variables are calculated, the EPLL output can be obtained by (13), generating the two quadrature signals

$$v'[n+1] = A'[n+1] \cdot \cos(\theta'[n+1])$$

$$qv'[n+1] = -A'[n+1] \cdot \sin(\theta'[n+1]).$$

This type of discretization method needs a more accurate tuning, due to the fact that the stable regions of the s-plane and z-plane are different. However, its major simplicity, compared to the Tustin or backward integration, benefits from the computational speed of this block

## MATLAB/SIMULATION RESULTS:

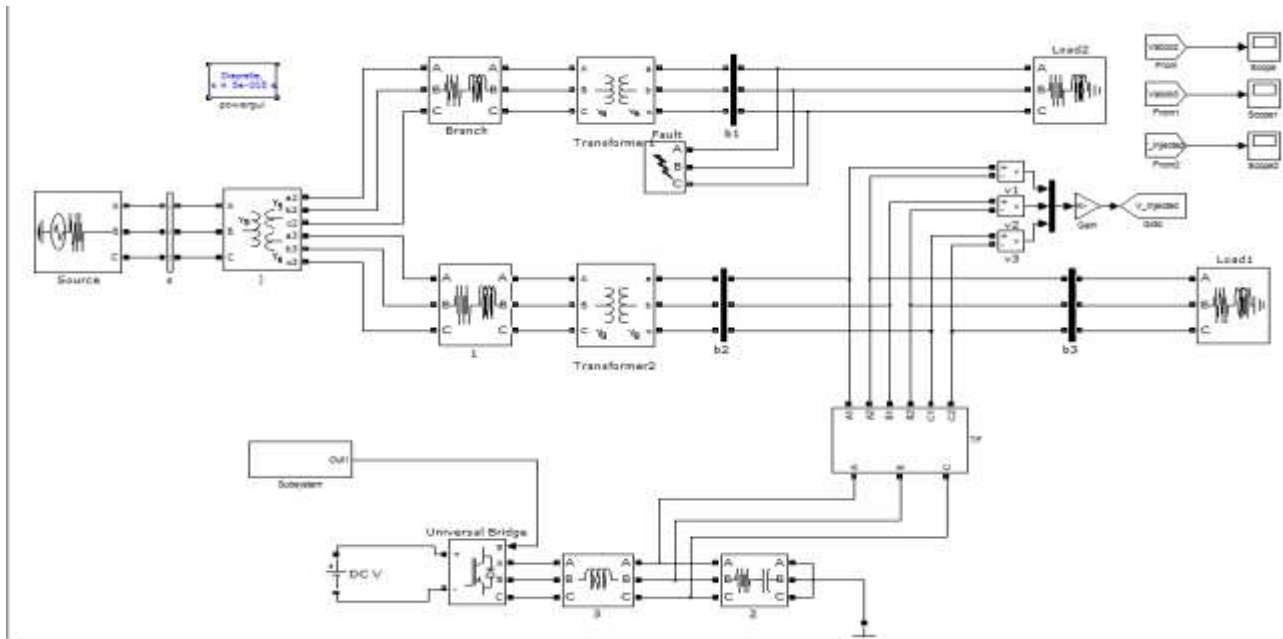

Fig. MATLAB/SIMULINK diagram of proposed system single phase sag

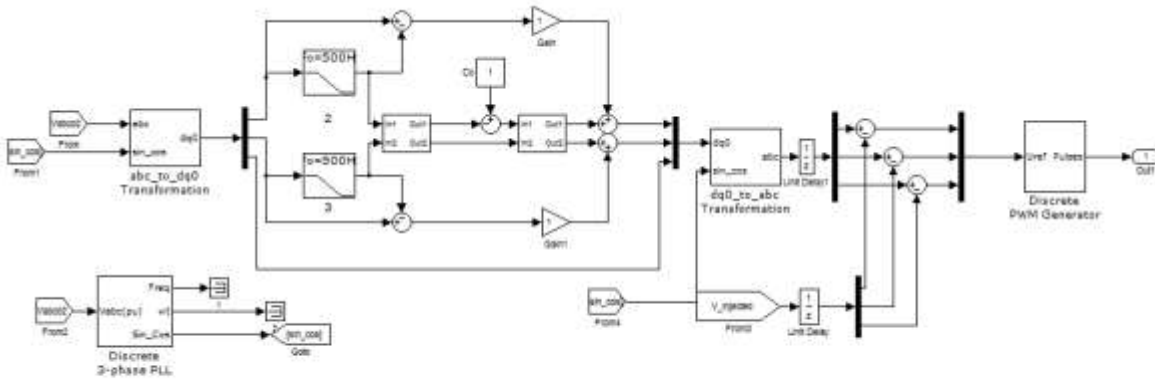

Fig controller Subsystem



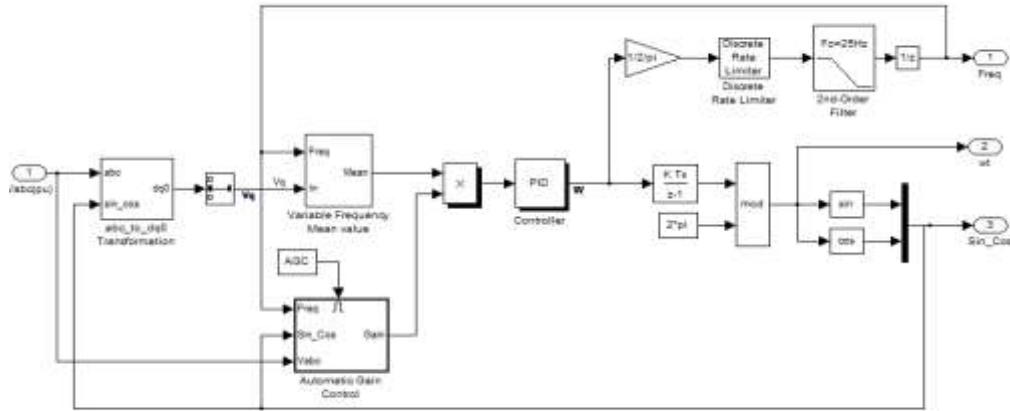

Fig Discrete phase PLL

**Single phase sag**

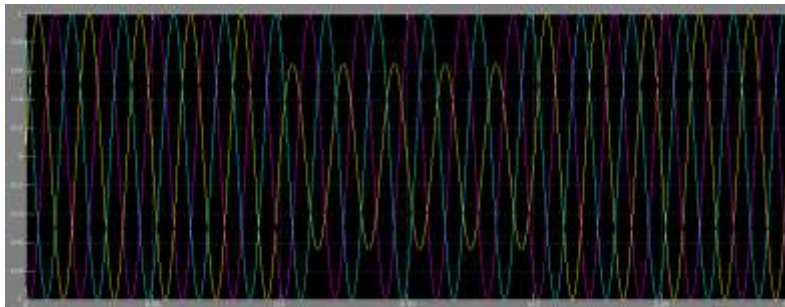

Fig. bus 2 voltage

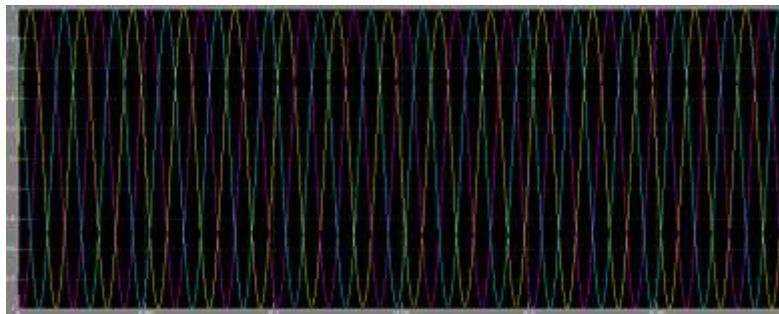

Fig.bus 3 voltage

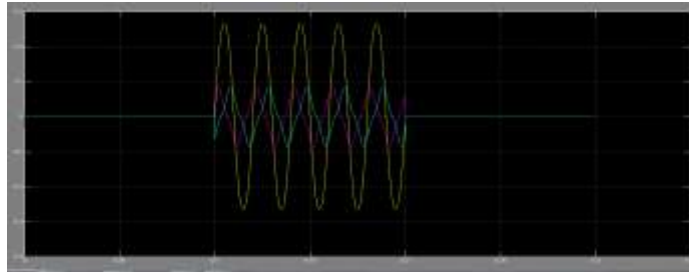

Fig. injected voltage

**three phase sag**

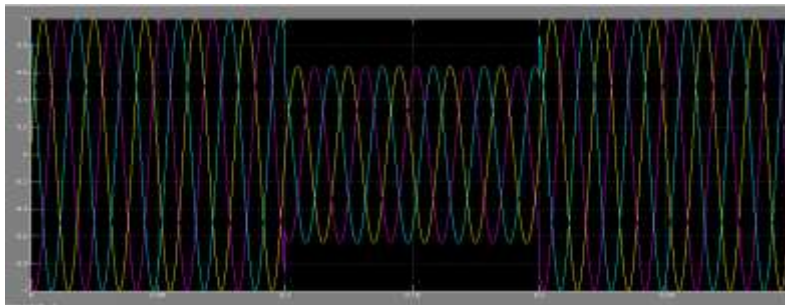

Fig. bus 2 voltage

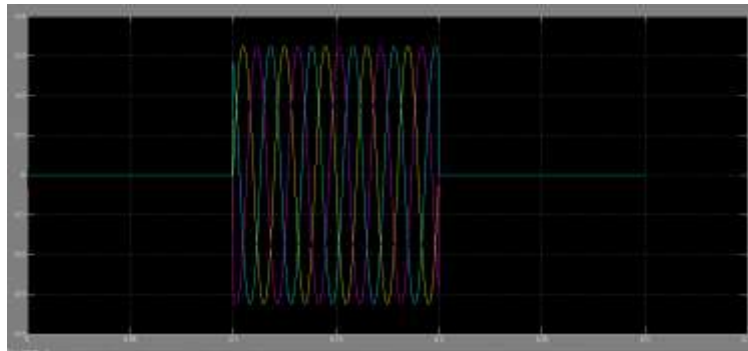

Fig. injected voltage

## CONCLUSION

In the process of synchronization of DG generated power with the utility, phase tracking is very essential for proper grid synchronization. A PLL can be used to obtain magnitude, frequency and phase





information for estimation of fundamental positive-sequence component of grid voltage. Accurate and fast estimation of these quantities can be used for control and protection of the system. Overall the grid synchronization system based on positive-sequence estimation is able to handle non ideal conditions well. The positive-sequence phase angle is tracked within acceptable margins and therefore the PLL system as given with the positive sequence estimation could indeed operate in a real life application

### REFERENCES

- [1] A. Zervos and C. Kjaer, *Pure Power: Wind Energy Scenarios for 2030*. Brussels, Belgium: European Wind Energy Association (EWEA), Apr. 2008. [Online]. Available: <http://www.ewea.org/index.php?id=11>
- [2] e-on, "Grid code—High and extra high voltage," Bayreuth, Germany. Apr. 2006. [Online]. Available: [http://www.pvupscale.org/IMG/pdf/D4\\_2\\_DE\\_annex\\_A3\\_EON\\_HV\\_grid\\_connection\\_requirements\\_ENENARHS2006de.pdf](http://www.pvupscale.org/IMG/pdf/D4_2_DE_annex_A3_EON_HV_grid_connection_requirements_ENENARHS2006de.pdf)
- [3] *PO-12.3 Requisitos de Respuesta Frente a Huecos de Tension de las Instalaciones Eolicas*, Comisión Nacional de Energía, Madrid, Spain, Oct. 2006.
- [4] *IEEE Standard for Interconnecting Distributed Resources With Electric Power Systems*, IEEE Std. 1547-2003, 2003.
- [5] *The Grid Code: Revision 31*, National Grid Electricity Transmission, Warwick, U.K., Oct. 2008, no. 3. [Online]. Available: <http://www2.nationalgrid.com/uk/industry-information/electricity-codes/grid-code/the-grid-code/>

### AUTHOR'S PROFILE:



**Nelaguduti Upendar** Received the B.Tech degree in Electrical & Electronics Engineering from Sri Sai Educational Society's Group of Institutions 2014 from JNTU, Hyderabad, Telangana, India and He is pursuing M.Tech in Electrical Power System (EPS) as specialization in the Department of Electrical & Electronics Engineering, SLC's Institute of Engineering and Technology, Affiliated to the JNTU Hyderabad, Telangana, India. His research area of interests is Power quality and Renewable energy sources.

E-mail id: [ursnani04@gmail.com](mailto:ursnani04@gmail.com)



**Ramavath Shankar Naik** received the B.Tech degree in Electrical Engineering from Vignana's Engineering College, Vadlamudi, Guntur, India, in 2006. He Completed M.E in Electrical Engineering with Power system Automation as specialization in the Department of Electrical Engineering, Andhra University College of Engineering (Autonomous), Visakhapatnam, He is currently an Associate Professor with the Department of Electrical & Electronic Engineering at SLC's Institute of Engineering and Technology, JNTU University, Hyderabad, Telangana, India. His area of interest lies in Power system operation and control, optimal operation of power systems and FACTS.

E-mail id: [shankar02234@gmail.com](mailto:shankar02234@gmail.com)